

PUMPS

PZ-9 (PZJ) DRILLING PUMP



SPECIFICATIONS

Maximum Input	1,000 BHP (746 kw)
Maximum RPM	130 RPM
Stroke Length	9" (229mm)
Piston Load	101,550 lbs. (451,717 N)
Pump Weight	24,368 lbs. (11,075 kg) average
Gear Ratio	4.48 :1



PISTON CYLINDER		DISPLACEMENT - DRILLING SERVICE				MAXIMUM PSI		PUMP RPM	JACKSHAFT RPM
DIAMETER		PER REVOLUTION		MAXIMUM FLOW RATE		PSI	bar		
in.	mm.	Gallons	Liters	GPM	LPM				
7	178	4.50	17.03	585	2214	2638	182	130	582
6.5	165	3.88	14.68	504	1909	3059	211		
6.25	159	3.59	13.57	466	1765	3309	228		
6	152	3.30	12.51	430	1626	3591	248		
5.5	140	2.78	10.51	364	1367	4273	295		
5	127	2.29	8.69	298	1129	5000	345		
4.5	114	1.86	7.04	242	915	5000	345		
4	102	1.47	5.56	191	723	5000	345		

Ratings are based on 90% mechanical efficiency and 100% volumetric efficiency

PZ-9 (PZJ) DRILLING PUMP

SPECIFICATIONS

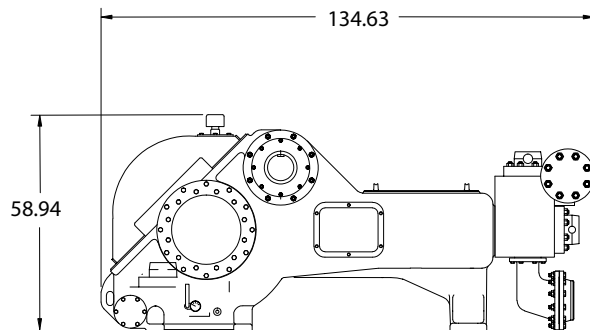
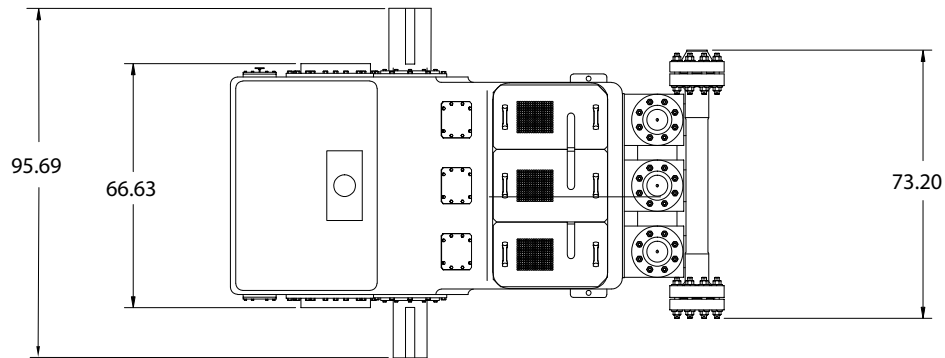

STANDARD FEATURES

- High-strength, cast nodular iron power frame, eccentric, connecting rods, and crossheads
- Full roller-bearing construction a eccentric mains, jackshift, connecting rods, and crosshead pins
- Heat-treated alloy steel, double helical AGMA drive gears
- Double extended jackshift for mounting sheaves or sprockets
- Replaceable bronze crosshead slides
- Splash lubrication with internal lube pump supplying pressurized oil to bearings, gears, and crosshead slides
- Ultra compact, heat-treated alloy steel, valve over valve, interchangeable fluid end modules
- Hydrostatic-tested cast steel discharge manifold
- API suction and discharge connections

OPTIONAL FEATURES

- Steel transportation and placement skid for pump only or larger maintenance skid with non-slip decking
- Centrifugal suction charging pump
- Suction stabilizer and/or discharge damper
- External electric-powered lube pump
- Fabricated, log-style suction manifold
- Full open valve seats
- Custom packaging available