

## PUMPS



# PZG (PZ-7) TRIPLEX DRILLING MUD PUMP

## SPECIFICATIONS

Maximum Input	550 BHP (410 kw)
Maximum RPM	145 RPM
Stroke Length	7" (178 mm)
Piston Load	64,400 lbs. (286,465 N)
Pump Weight	16,765 lbs. (7,620 kg)
Gear Ratio	4.625 :1



PISTON CYLINDER		DISPLACEMENT - DRILLING SERVICE				MAXIMUM PSI		PUMP RPM	JACKSHAFT RPM
DIAMETER		PER REVOLUTION		MAXIMUM FLOW RATE		PSI	bar		
in.	mm.	Gallons	Liters	GPM	LPM				
7	178	3.5	13.24	507	1920	1672	115	145	671
6.5	165	3.02	11.42	437	1656	1940	134		
6.25	159	2.79	10.56	404	1531	2098	145		
6	152	2.57	9.73	373	1411	2276	157		
5.5	140	2.16	8.18	313	1186	2709	187		
5	127	1.78	6.76	259	980	3278	226		
4.5	114	1.45	5.47	210	794	4047	279		
4	102	1.14	4.32	166	627	5000	345		

Weight: Complete pump with large steel skid - 18,000 pounds.  
Ratings are based on 90% mechanical efficiency and 100% volumetric efficiency.

# PZG (PZ-7)

## TRIPLEX DRILLING MUD PUMP

### SPECIFICATIONS

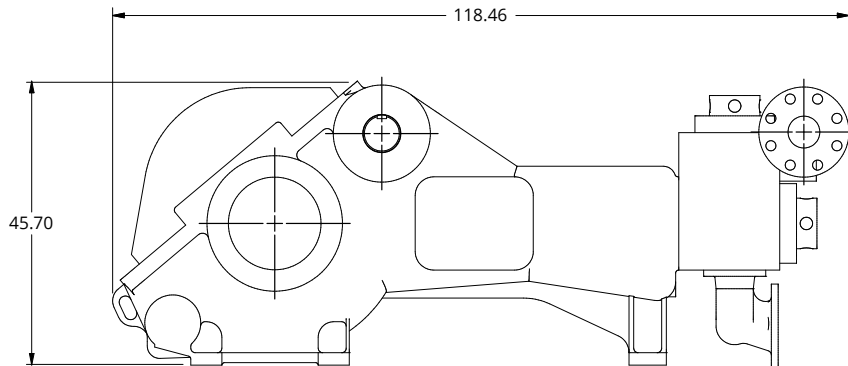
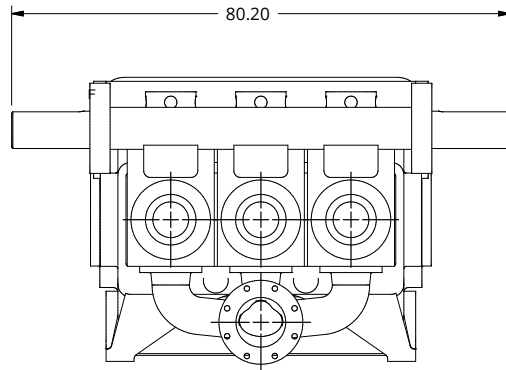

### STANDARD FEATURES

- Nodular iron power frame, eccentric, connecting rods, and crossheads
- Double-row spherical roller bearings carry eccentric
- Double-extended Jackshift carried on heavy-duty straight roller bearings
- Dual roller-bearing connecting rod
- Heat-treated alloy steel main gears are bolted to the eccentric
- Replaceable bronze crosshead slides
- Full splash lubrication, with oil pump to feed working parts
- Heat-treated alloy steel, interchangeable fluid cylinders
- Three-rib API-7 urethane insert valves and seats
- Replaceable-type element oil filter and oil pressure gauge
- Threaded valve covers
- Complete piston washing and lubrication system

### OPTIONAL FEATURES

- Steel skid under pump only
- Large steel skid with non-skid decking
- Centrifugal suction charging pump
- Rubber valve inserts
- Suction and/or discharge dampeners
- Oil heat exchanger
- External electric-powered lube pump
- Fabricated suction manifold
- Complete package assembly
- Full open valves