

PUMPS

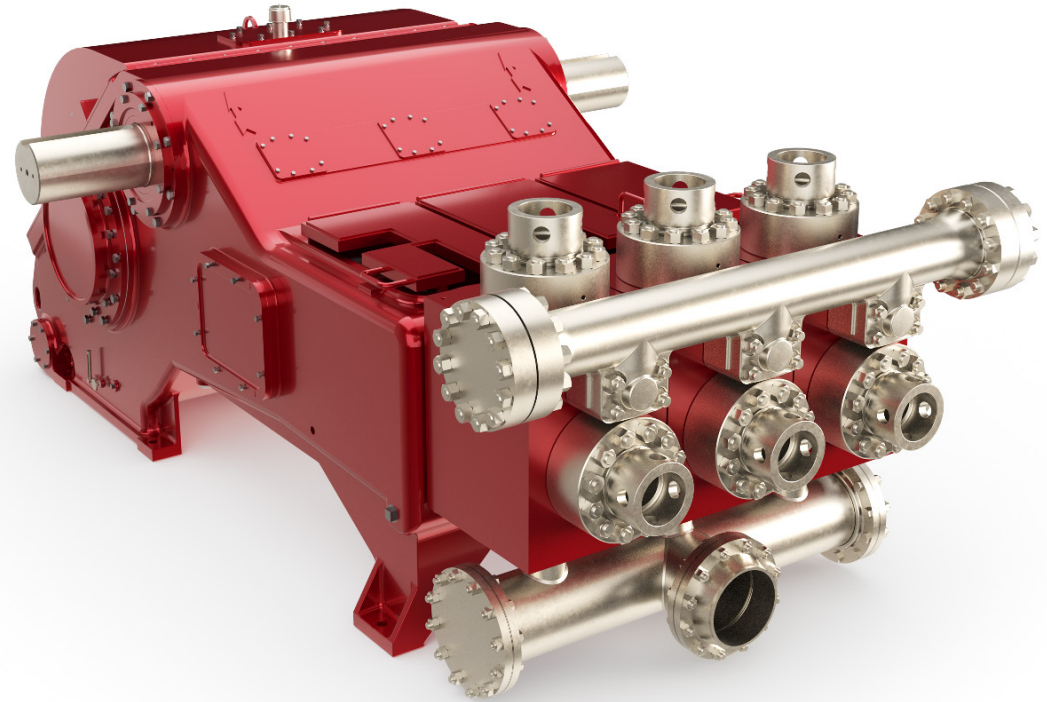

PZ 1600 DRILLING MUD PUMP

Known for its durability and ease of maintenance, the PZ 1600 is a 1600hp triplex drilling pump that features 7,500 psi modules and an 11" stroke. The PZ 1600's superior performance is attributed to its proven design, which is made of 100 percent cast frame and the highest quality of parts. Packaged with Redline™ Series consumables, customers can expect unmatched performance while lowering their total cost of ownership.



SPECIFICATIONS

Maximum Input	1,600 BHP (1,491 kW)
Maximum RPM	115 RPM
Stroke Length	11 in (279 mm)
Piston Load	150,300 lb (668,568 N)
Pump Weight	37,000 lbs (16,815 kg)
Gear Ratio	4.38:1

7,500 PSI FLUID END CYLINDER

PLUNGER/PISTON		DISPLACEMENT - DRILLING SERVICE				MAXIMUM PSI		PUMP RPM	JACKSHAFT RPM
DIAMETER		PER REVOLUTION		PER MINUTE		PSI	bar		
in.	mm.	Gallons	Liters	GPM	LPM				
7	178	5.50	20.81	632	2393	3904	269	115	504
6.5	165	4.74	17.94	545	2064	4527	312		
6.25	159	4.38	16.59	504	1908	4897	338		
6	152	4.04	15.29	465	1758	5314	366		
5.5	140	3.39	12.85	390	1478	6324	436		
5	127	2.80	10.62	323	1221	7500	517		

Ratings shown are for 5,000 PSI Fluid End Cylinder. 5000 PSI modules also available.

Weight: Complete pump with large steel skid - 41,400 pounds.

Ratings are based on 90% mechanical efficiency and 100% volumetric efficiency

PZ 1600

DRILLING MUD PUMP

SPECIFICATIONS

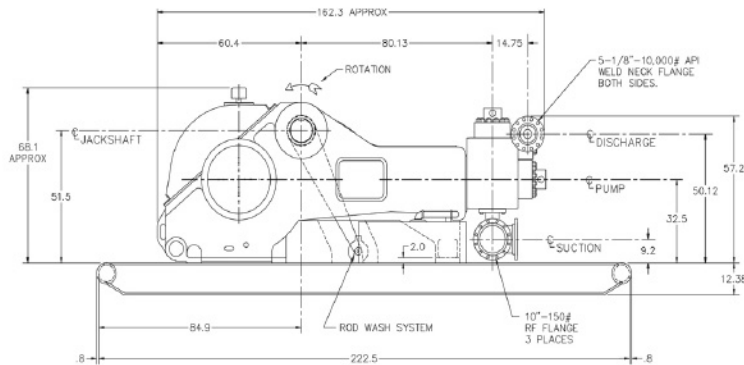
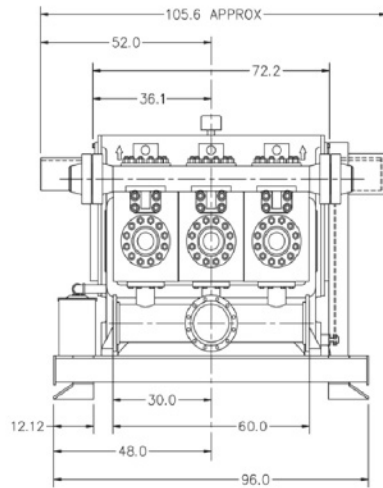

NOTE: Installation drawing shown with Next Generation fluid end geometry. Additional drawings are available from engineering per application.

STANDARD FEATURES

- Falcon technology for improved serviceability
- Bore seal valve cover and wear plate design for improved seal performance
- Optimized internal module geometry minimizing operating stress
- Full roller bearing construction
- High strength nodular frame, eccentric, conn-rods and crossheads in a light-weight, compact design
- Heat treated alloy steel, double helical AGMA drive gears
- Double extended jackshift for mounting sheaves or sprockets
- Replaceable bronze crossheads slides
- Full roller bearing construction at eccentric mains, jackshift, connecting rods, and crosshead pins

OPTIONAL FEATURES

- Steel transportation and placement skid for pump only or larger maintenance skid with non-slipping deck
- Centrifugal suction charging pump
- Suction stabilizer and/or discharge damper
- External electric powered lube pump
- Fabricated, suction manifold
- Custom packaging available
- Discharge manifold