

PUMPS



PZH (PZ-8) TRIPLEX DRILLING MUD PUMP

SPECIFICATIONS

Maximum Input	750 BHP (559 kw)
Maximum RPM	145 RPM
Stroke Length	8" (203 mm)
Piston Load	76,800 (341,623 N)
Pump Weight	19,500 lbs. (8,850 kg)
Gear Ratio	4.5 :1

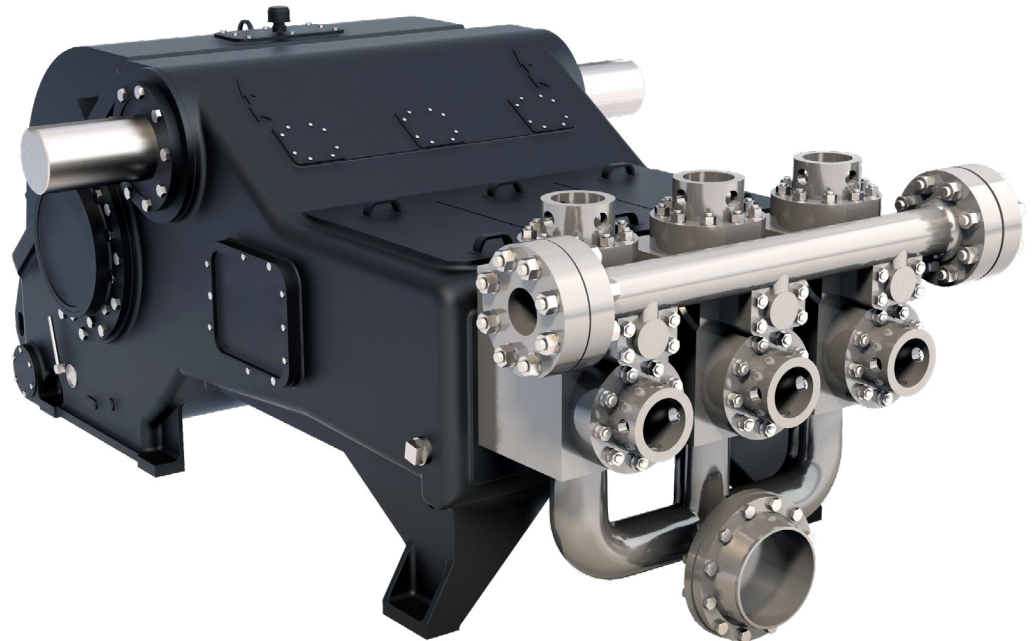

PISTON CYLINDER		DISPLACEMENT - DRILLING SERVICE				MAXIMUM PSI		PUMP RPM	JACKSHAFT RPM
DIAMETER		PER REVOLUTION		MAXIMUM FLOW RATE		PSI	bar		
in.	mm.	Gallons	Liters	GPM	LPM				
7	178	4.00	15.14	580	2195	1996	138	145	653
6.5	165	3.45	13.05	500	1892	2314	160		
6.25	159	3.19	12.07	462	1750	2503	173		
6	152	2.94	11.12	426	1612	2716	187		
5.5	140	2.47	9.34	358	1355	3232	223		
5	127	2.04	7.72	296	1120	3911	270		
4.5	114	1.65	6.25	240	907	4829	333		
4	102	1.31	4.94	189	717	5000	345		

Weight: Complete pump with large steel skid - 22,500 pounds.
 Ratings are based on 90% mechanical efficiency and 100% volumetric efficiency.

PZH (PZ-8)

TRIPLEX DRILLING MUD PUMP

SPECIFICATIONS

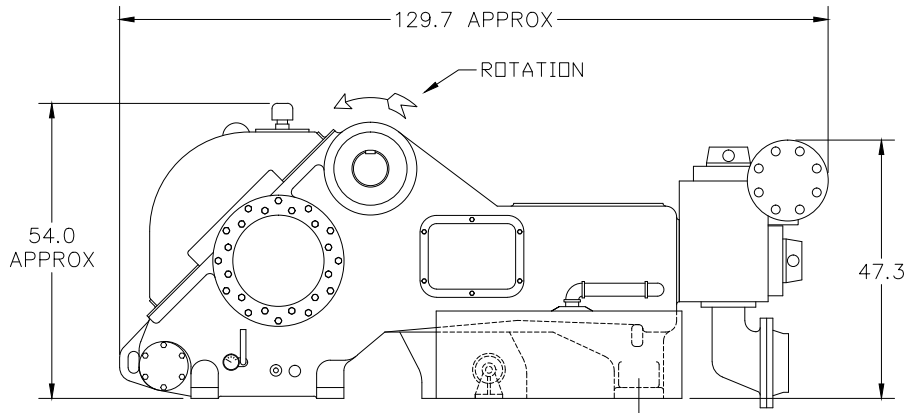
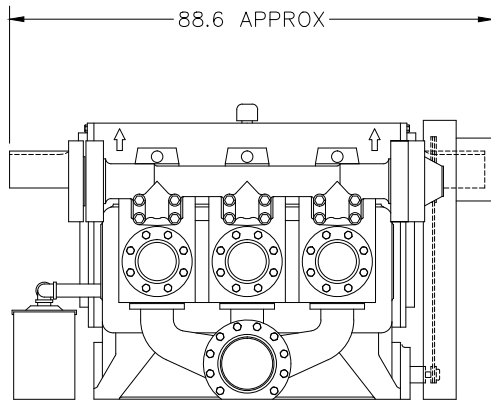

STANDARD FEATURES

- Nodular iron power framer, eccentric, connecting rods, and crossheads
- Double-row-spherical roller bearings carry eccentric
- Double extended Jackshift carried on heavy-duty straight roller bearings
- Dual roller bearing connecting rod
- Heat-treated alloy steel, interchangeable fluid cylinders
- Three-rib API-7 urethane insert valves and seats
- Replaceable-type element oil filter and oil pressure gauge
- Threaded valve covers
- Complete piston washing and lubrication system

OPTIONAL FEATURES

- Steel skid under pump only
- Large steel skid with non-skid decking
- Centrifugal suction charging pump
- Rubber valve inserts
- Full open valves
- Suction and/or discharge dampeners
- Oil heat exchanger
- External electric powered lube pump
- Fabricated suction manifold
- Custom packaging available