

PUMPS



GD 800HDD HORIZONTAL DIRECTIONAL DRILLING PUMP

Built on GD Energy Products' legacy of product innovation in pumping technology, the GD 800HDD pump is designed to serve a wide variety of HDD applications. This compact, lightweight pump features a high rod load and delivers a flow rate of over 1,000 GPM. The pump's innovative fluid end design also accelerates valve changeout time by more than 5X, resulting in reduced maintenance downtime during operations.

SPECIFICATIONS

Output Flow	1,000 GPM
Maximum Pressure	2,698 PSI
Maximum Crankshaft Speed	275 RPM
Max Input Power	800 BHP (597 kW)
Gear Ratio	4.6:1
Number of Pistons	5
Stroke Length	6" (152.4 mm)
Weight without GB	6,492 lb (2,944 kg)
Weight with GB	7,483 lb (3,394 kg)
Brake Horsepower (BHP)	800
Rod Load	53,000 lb (236 kN)
Dimensions without GB	67.51"L x 52.09"W x 30.28"H
Dimensions with GB	67.51"L x 74.37"W x 30.28"H

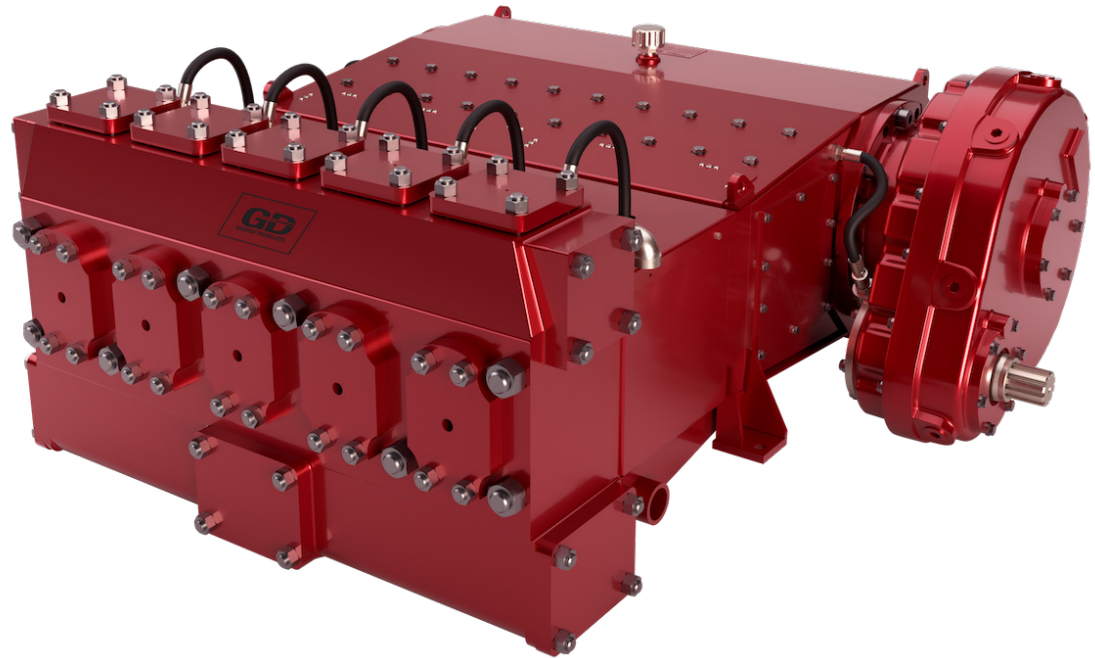

PISTON DIAMETER	DISPLACEMENT PER REVOLUTION	DISPLACEMENT AT PUMP RPM (HDD SERVICE)																					
		50				100				150				200				275					
in.	mm.	Gallons	Liter	GPM	LPM	PSI	bar	GPM	LPM	PSI	bar	GPM	LPM	PSI	bar	GPM	LPM	PSI	bar	GPM	LPM	PSI	bar
6	152	3.67	13.90	183.6	695	1874	129.2	367.2	1390	1874	129.2	550.8	2085	1874	129.2	734.4	2780	1680	115.8	1010	3823	1222	84
5.5	140	3.09	11.68	154.3	584	2230	154	308.6	1168	2230	153.8	462.8	1752	2230	153.8	617.1	2336	2000	137.9	848.5	3212	1454	100.2
5	127	2.55	9.65	127.5	482.6	2698	186	255	965.3	2698	186	382.5	1448	2698	186	510	1931	2420	166.9	701.3	2655	1760	121.3
INPUT POWER		HP		223				446				669				800				800			
		kW		166				333				499				597				597			

Note: For max flow applications, please consult GDEP Engineering for approval.

GD 800HDD

HORIZONTAL DIRECTIONAL DRILLING PUMP

SPECIFICATIONS

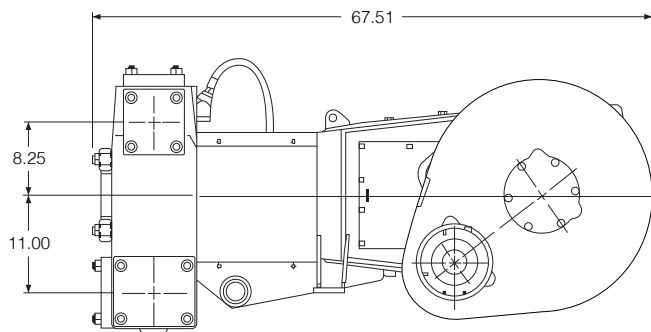
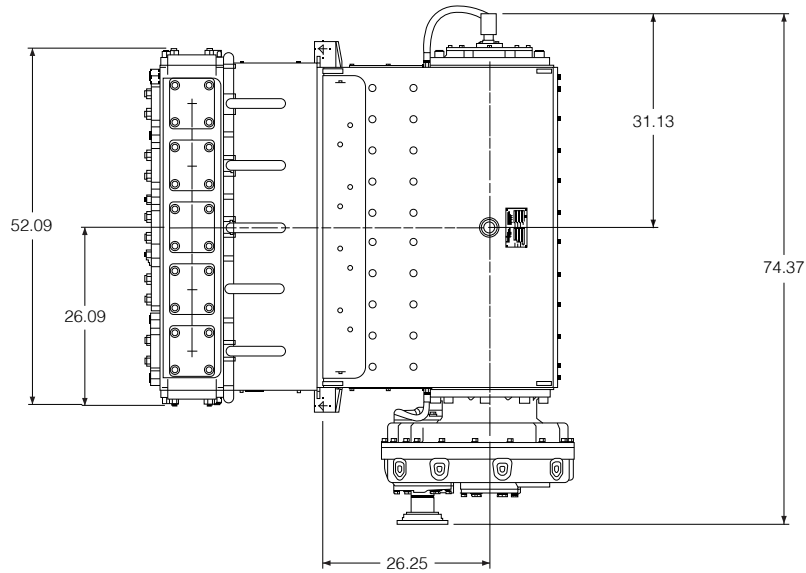

Note: Line drawings are available from Engineering application

STANDARD FEATURES

- Featuring GD Energy Products' industry leading Redline Consumables for extended maintenance intervals
- Full cast ductile iron frame fluid end offers superior strength
- Large valve cover access panels for easy valve change outs
- All parts 100% made in the USA, guaranteeing build quality and reliability in the field
- Upgraded internal components and seal housing prevent contamination
- Coated crankshaft bearings to extend power end life
- Next generation fluid end technology with innovative geometry to minimize stress
- Left or right side suction and discharge connections
- Left or right handed keyed shaft extension
- Pressure lubricated power end (via engine driven oil pump - not supplied)
- Clamp style connections between piston rod and crosshead extensions
- Rod wash spray bar and baffles
- Teardrop Spur Gearbox
- Patented Falcon retainer technology offers a significant 5X increase in speed for valve changes